

# Monolithic SP4T PIN Diode Switch With Integrated Bias Network

MA4SW424B-1

## Features

- Frequency of Operation: 24 +/- 2 GHz
- Fully Integrated Bias Network
- Series Diode, Low Current Consumption Design : +12mA for Insertion Loss, 0 Volts for Isolation
- The Device is Wire Bond Compensated at all RF Ports for RF Matching
- Rugged, Fully Monolithic, Glass Encapsulated Construction

## Description

The MA4SW424B-1 device is a SP4T Switch with Integrated Bias Network utilizing M/A-COM's HMIC™ (Heterolithic Microwave Integrated Circuit) Process, US Patent 5,268,310. This process allows the incorporation of silicon pedestals that form series and/or shunt diodes or vias by imbedding them in a low loss, low dispersion glass. By using small spacing between elements, this combination of silicon and glass gives HMIC devices exceptional low loss and high isolation performance with exceptional repeatability through lower millimeter frequencies.

Four mil square RF bond pads facilitate the use of low inductance ribbon bonds, while gold backside metalization allows for manual or automatic chip bonding using 80Au/20Sn, Sn62/Pb36/Ag2 solders or electrically conductive silver epoxy. Each RF Bond Pad has adjacent wire-bonded tuning pads available to optimize the RF Match for a particular frequency response.

## Applications

The MA4SW424B-1 SP4T Device is Designed for 24 GHz Automotive Switching Applications. Insertion Loss is Achieved with + 12 mA @ + 4 V and Isolation is Achieved with 0V D.C. Bias. The RF Bias Network is Integrated into the HMIC Switch for ease of use and space consideration.

## Absolute Maximum Ratings<sup>1</sup>

@ TA = +25 °C (unless otherwise specified)

Parameter	Value
Operating Temperature	-65 °C to +125 °C
Storage Temperature	-65 °C to +150 °C
RF C.W. Incident Power @ +20 mA	+ 30 dBm
DC Bias Current	+40 mA

1. Exceeding any of these values may result in permanent damage

## Outline Drawing

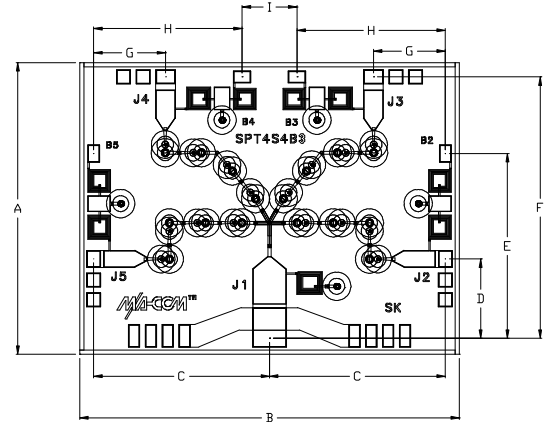

## Nominal Die Dimensions

Dim	Inches		Millimeters	
	Min	Max	Min	Max
A	0.100	0.104	2.54	2.64
B	0.131	0.135	3.33	3.43
C	0.061	0.062	1.55	1.57
D	0.027	0.028	0.70	0.72
E	0.064	0.065	1.63	1.65
F	0.091	0.092	2.31	2.33
G	0.025	0.026	0.63	0.65
H	0.052	0.052	1.31	1.33
I	0.019	0.020	0.48	0.50

Note:

1. RF and DC Bond Pads are 4 mils (0.10 mm) Square

Electrical Specifications @ T<sub>A</sub> = + 25 °C (On-Wafer Measurements Only)

Parameters	Frequency	Minimum	Nominal	Maximum	Units
Insertion Loss	24 GHz	-	3.0	3.5	dB
Isolation	24 GHz	37	40	-	dB
Input Return Loss	24 GHz	-	9	-	dB
Switching Speed <sup>1</sup>	24 GHz	-	200	-	nS

1. Typical Switching Speed measured from 10 % to 90 % of detected RF signal driven by TTL compatible drivers using RC Output Spiking Network, where R = 50 – 200 Ω, C = 390 – 560 pF.

Operation of the MA4SW424B-1

Operation of the MA4SW424B-1 Series PIN Diode Switch is achieved by the Application of D.C. Current ( 12mA ) to the Bias Port of the Selected Insertion Loss Port and 0V Bias for the Isolated Ports. The control currents should be supplied by constant current sources.

Driver Connections for the MA4SW424B-1

D.C. Bias Conditions				RF Output Conditions			
B2	B3	B4	B5	J1-J2	J1-J3	J1-J4	J1-J5
+12 mA	0 Volts	0 Volts	0 Volts	Low Loss	Isolation	Isolation	Isolation
0 Volts	+12 mA	0 Volts	0 Volts	Isolation	Low Loss	Isolation	Isolation
0 Volts	0 Volts	+12 mA	0 Volts	Isolation	Isolation	Low Loss	Isolation
0 Volts	0 Volts	0 Volts	+12 mA	Isolation	Isolation	Isolation	Low Loss

### Assembly Considerations

The following precautions should be observed for successful assembly of the die.

### Cleanliness

These chips should be handled in a clean environment. Do not attempt to clean die after installation.

### Electro-Static Sensitivity

The MA4SW424B-1 Series PIN Diode Switch is ESD, Class 1 sensitive. The proper ESD handling procedures should be used.

### Wire Bonding

Thermosonic wedge or Ball bonding using 0.003" x 0.00025" Gold ribbon or 0.001" diameter Gold wire is recommended. A stage temperature of 150 °C and a force of 18 to 22 grams should be used. Ultrasonic energy should be adjusted to the minimum required. RF bonds should be as short as possible for lowest parasitics. One mil diameter Gold Wire results in approximately 0.02 nH / mil Length.

### Mounting

These chips have TiPtAu back metal. They can be die mounted with a gold-tin eutectic solder preform or electrically conductive epoxy. Mounting surface must be clean and flat.

### Eutectic Die Attachment

An 80/20 Gold-Tin eutectic solder preform is recommended with a work surface temperature of 255 °C and a tool tip temperature of 265 °C. When hot gas is applied, the tool tip temperature should be 290 °C. The chip should not be exposed to temperatures greater than 320 °C for more than 20 seconds. No more than three seconds should be required for the attachment. Sn62/Pb36/Ag2 Solder is also acceptable for use.

### Electrically Conductive Epoxy Die Attachment

Assembly should be preheated to 125-150 °C. A Controlled amount of Electrically Conductive Epoxy should be used, approximately 1 to 2 mils thickness for Best Electrical and Thermal Conductivity. A thin epoxy fillet should be visible around the perimeter of the chip after placement. Cure epoxy per manufacturer's time-temperature schedule.

### MA4SW424B-1 Topology

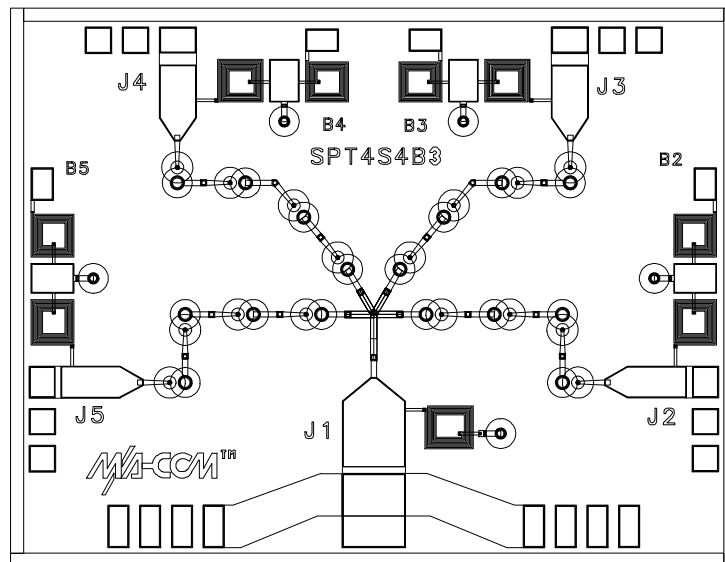

Microwave Performance

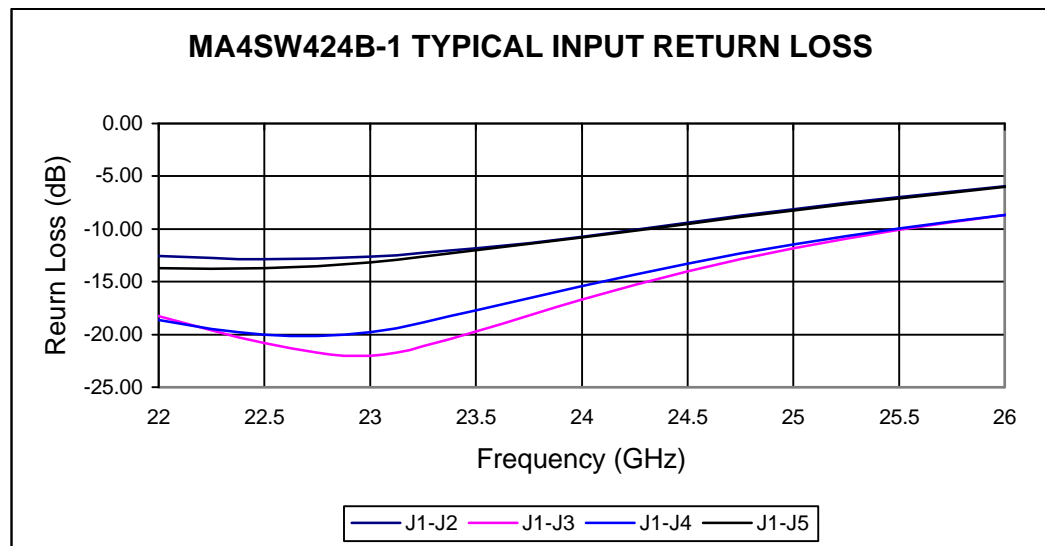
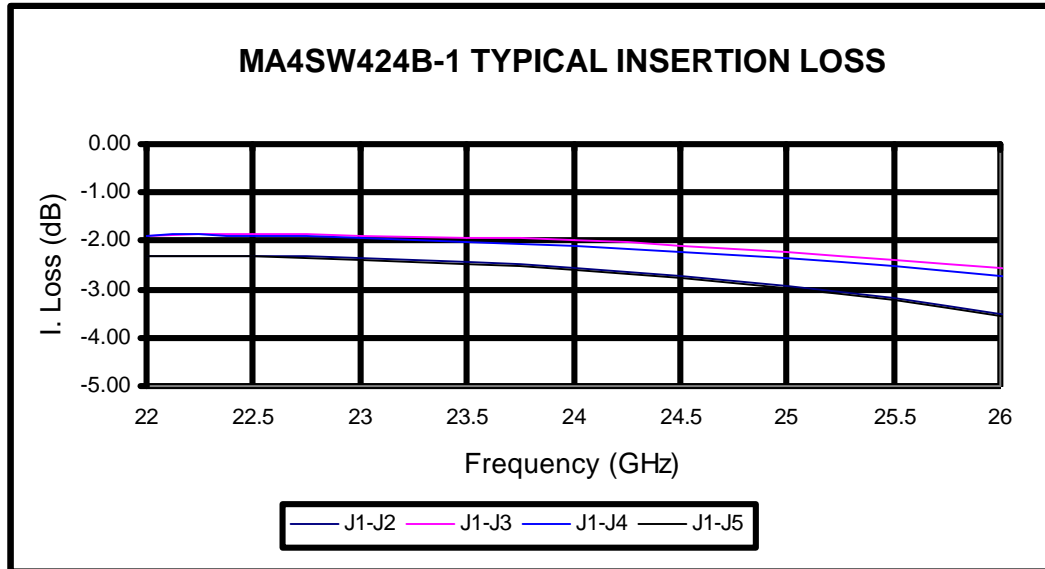

Microwave Performance

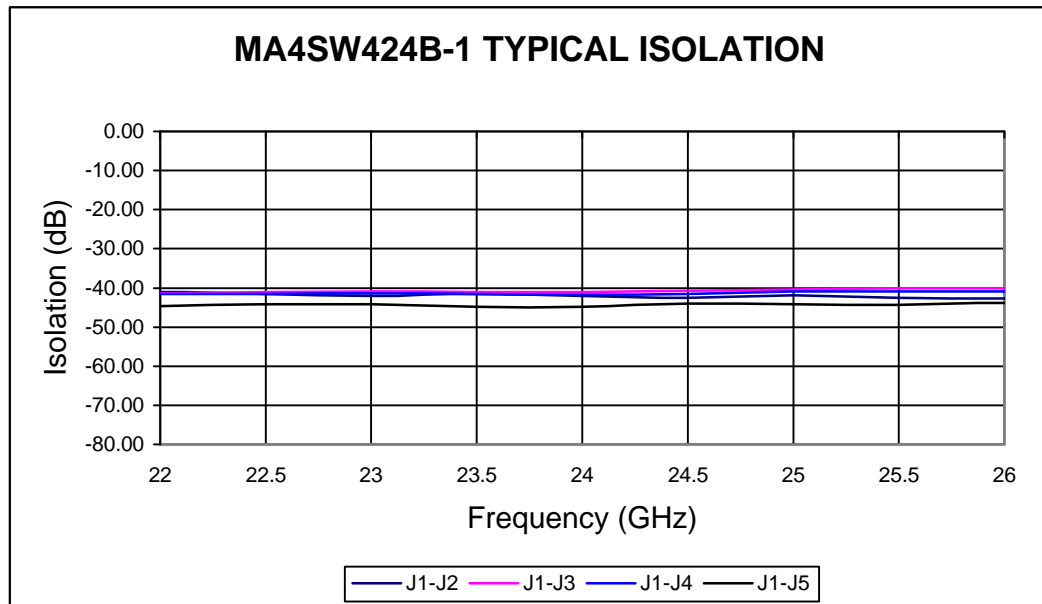
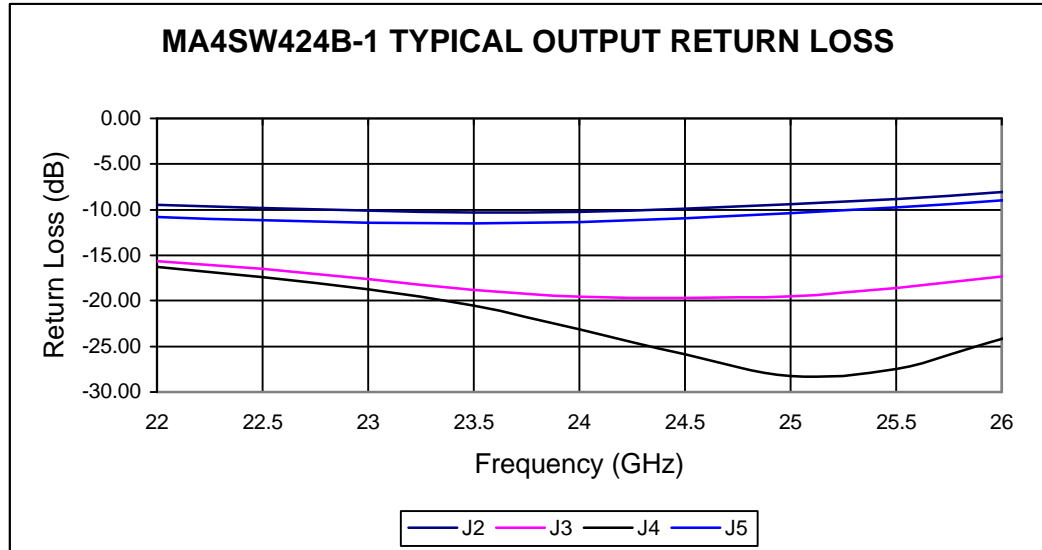

**RF Performance Notes**

- The Graphs Represent On-Wafer measurements only. Due to the nature of the design and the implementation of the device, Ribbon / Wire bonding will shift the frequency response for better RF Match at 24GHz.
  - Recommended Wire: (2) 1mil dia. wire, 10mils long or less per RF bond pad.
  - Recommended Ribbon: (1) ¼ x 3mil Ribbon, 10 mils long or less per RF bond pad.
- Tuning Stubs are positioned adjacent to Each RF Pad to Optimize Performance.

MA4SW424B-1 Schematic

